

REACH & RoHS  
COMPLIANT

REV.	ECN / DESCRIPTION	BY	DATE
A0	NEW	ZG.Hu	2018.06.13

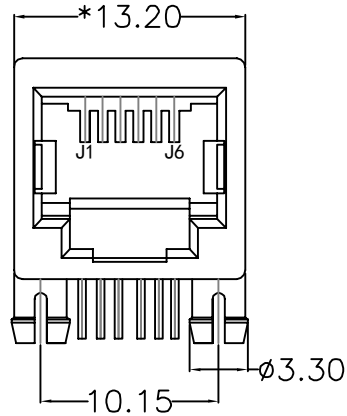

FRONT VIEW

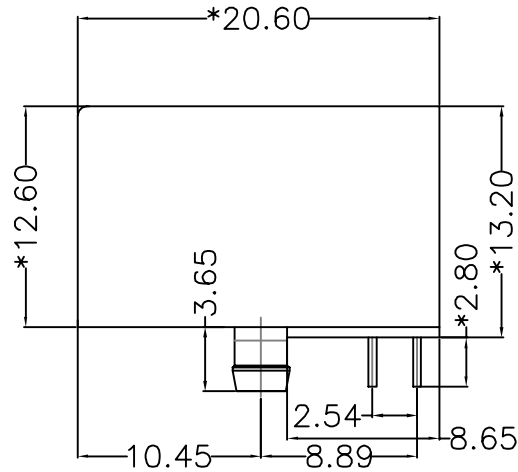

RIGHT SIDE VIEW

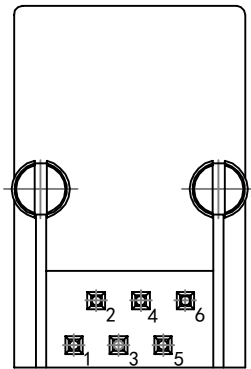

BOTTOM VIEW

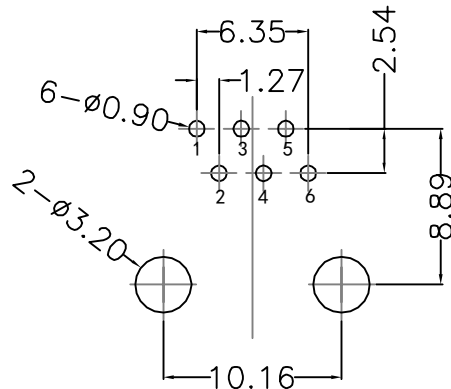

RECOMMENDED PCB LAYOUT  
VIEWED FROM COMPONENT SIDE

**MATERIAL:**

HOUSING: PBT,UL94V-0,BLACK.  
TERMINAL: PHOSPHOR BRONZE  $\varnothing=0.46\text{MM}$ , G/FU" GOLD PLATING.

**MACHANICAL:**

DURABILITY: 750 CYCLES MIN,12.5MM/MINUTE.  
INSERTION FORCE: 2.2KG.F MAX.  
RETENTION STRENGTH : 7.7KG.F BETWEEN JACK AND PLUG.  
OPERATING TEMPERATURE:  $-40^{\circ}\text{C}\sim+85^{\circ}\text{C}$ .  
STORAGE TEMPERATURE:  $-40^{\circ}\text{C}\sim+85^{\circ}\text{C}$ .  
ALL CRITICAL DIMENSIONS WITH "\*"

**ELECTRICAL:**

VOLTAGE: 125 VOLTS AC.  
CURRENT RATING : 1.5AMP.  
DIELECTRIC STRENGTH: 1000 VAC RMS 50HZ OR 60HZ,1MIN.  
INSULATION RESISTANCE: 500 MEGA OHMS MIN. INITIAL  
AFTER 500V DC FOR 1 MINUTE.  
CONTACT RESISTANCE: SINGLE TERMINAL 30 MILLIOHMS MAX.  
INITIAL 50 MILLIOHMS MAX. AFTER  
DURABILITY TEST.



**WOHU** 苏州沃虎电子科技有限公司  
Su Zhou Wo Hu Electronic Tech.Co.,Ltd.

TITLE: RJ11 1*1 5921全塑	SIZE A4	UNITS MM[INCH]	GENERAL TOLERANCES UNLESS SPECIFIED		APPROVED BY: JP.Gong
PART NO.: SYT59211166IWA1DY1J022	SACLE 1:1	REV A0	$x\pm 0.35$	$x^{\circ}\pm 3.0^{\circ}$	CHECKED BY: TW.Xu
REMARK:	SHEET 1/1		$.xx\pm 0.25$	$.xx^{\circ}\pm 1.5^{\circ}$	DESIGND BY: ZG.Hu
			$.xxx\pm 0.10$	$.xxx^{\circ}\pm 1.0^{\circ}$	