

受控编号: QR-SF-002-002

CUSTOMER DRAWING

REV. 版本	ECN NO. 变更说明	DATE 日期
A	First issued	20181022
B	UPDATE DRAWING	20190529

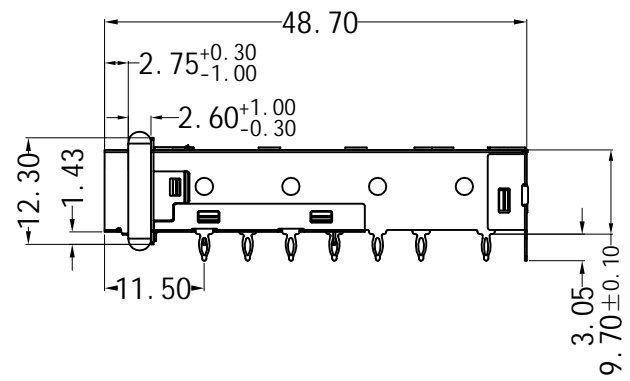
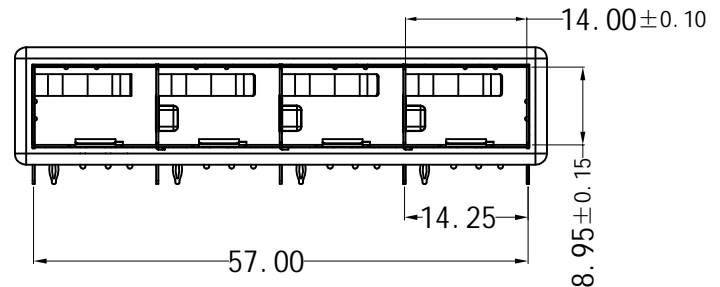
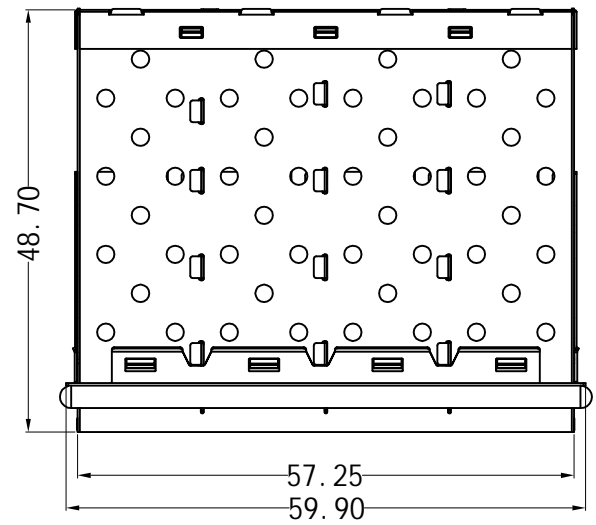

NOTE:  
 1. DESCRIPTION                      Q'ty                      MATERIAL                      PLATING  
 SFP CAGE                              1PCS                      COPPER ALLOY T=0.25                      N/A  
 GASKET FLANGE                      1PCS                      COPPER ALLOY T=0.25                      N/A  
 EMI GASKET                            1PCS                      PLATED FILLED SILICONE                      N/A  
 2. TEMPERATURE:  
 OPERATION: -40° C~+85° C  
 STORAGE: -55° C~+105° C

PART NUMBER	PART NUMBER	DESCRIPTION
10711114W001	K869-00-Y076	SFP+ 1X4 CAGE (Press-fit) W/O LOGO
10711114W002	K869-00-Y075	SFP+ 1X4 CAGE (Press-fit) W/ LOGO

RoHS Compliant

**WOHU 苏州沃虎电子科技有限公司**  
 Tel:4001048018 http://www.wohu-tek.com

TOLERANCES 公差  
 .X ±0.25  
 .XX ±0.13  
 .XXX ±0.10  
 ANGLES: ±2°

Material: 材质 SEE NOTE  
 Finish: 电镀 SEE NOTE  
 SHEET 1 OF 2  
 第 页 共 页

Designed: 设计 孟德权  
 Checked: 审核 田立春  
 Approved: 核准 程牧

NAME: 名称 SFP+ 1X4 CAGE  
 DWG NO: 图号 ESFP10120201-C  
 PART NO: 料号 SEE TABLE  
 REV. 版本 B

第三视角  
 A4  
 SIZE

SCALE 比例 1:1  
 UNIT 单位 mm  
 CUSTOMER: 客户 N/A  
 MODEL NO: 模号 N/A

受控编号: QR-SF-002-002

CUSTOMER DRAWING

REV. 版本	ECN MO. 变更说明	DATE 日期

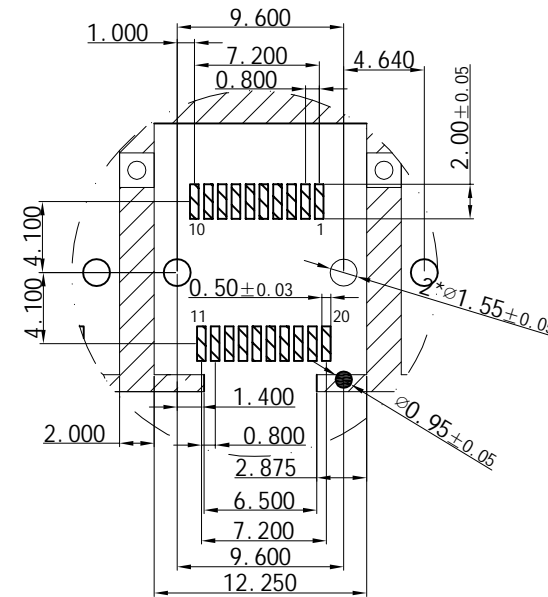
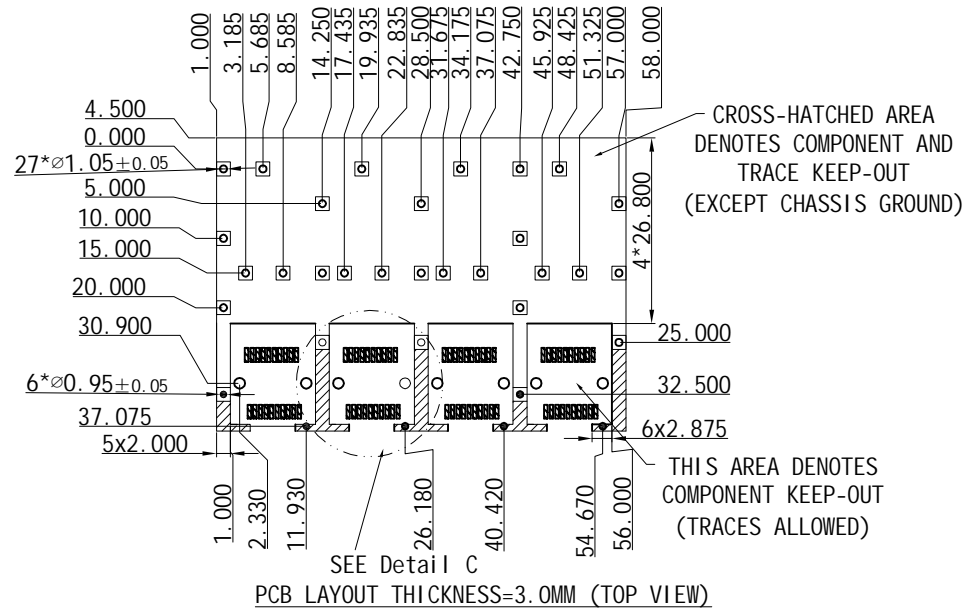
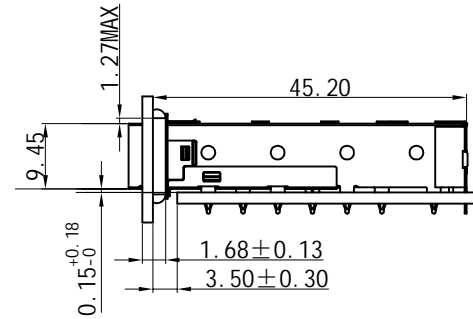
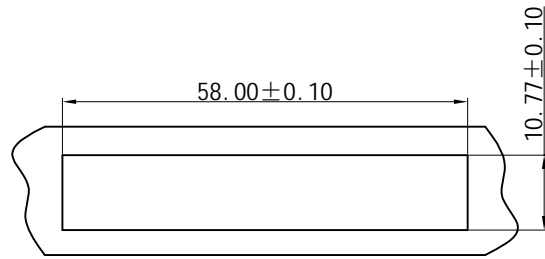

Detail C  
SCALE 2.5:1

RoHS Compliant

**WOHU 苏州沃虎电子科技有限公司**  
Tel:4001048018 http://www.wohu-tek.com

TOLERANCES 公差  
.X ±0.25  
.XX ±0.13  
.XXX ±0.10  
ANGLES: ±2°

Material: 材质: SEE NOTE  
Finish: 电镀: SEE NOTE  
SHEET 2 OF 2  
第 页 共 页

Designed: 设计: 孟德权  
Checked: 审核: 田立春  
Approved: 核准: 程牧

NAME: 名称	SFP+ 1X4 CAGE	REV. 版本
DWG NO: 图号	ESFP10120201-C	B
PART NO: 料号	SEE TABLE	

第三视角

A4 SIZE	SCALE 比例: 1:1	UNIT 单位: mm	CUSTOMER: 客户: N/A	MODEL NO: 模号: N/A
---------	---------------	-------------	-------------------	-------------------