

REACH & RoHS
COMPLIANT

| REV. | ECN / DESCRIPTION | BY | DATE |
|------|-------------------|-------|------------|
| A0 | NEW | MQ.Qu | 2017.10.20 |

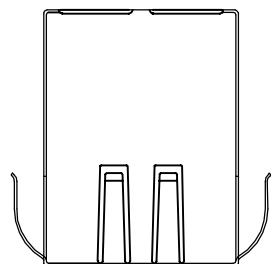

TOP VIEW

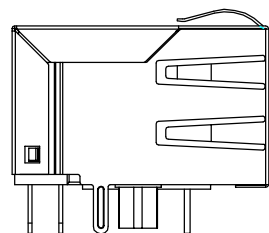

LEFT SIDE VIEW

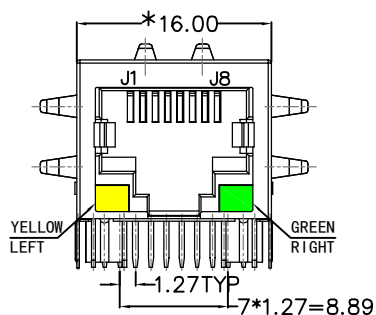

FRONT VIEW

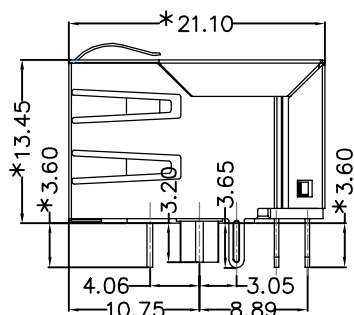

RIGHT SIDE VIEW

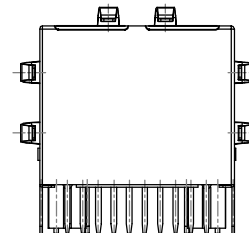

BACK VIEW

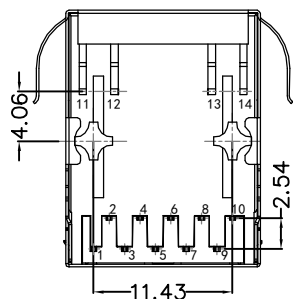

BOTTOM VIEW

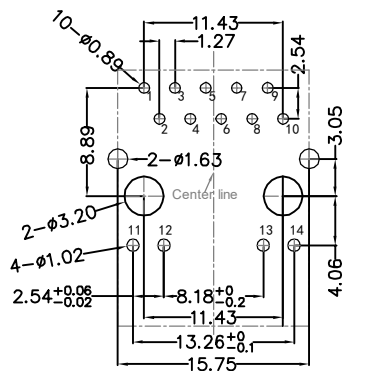

RECOMMENDED PCB LAYOUT
VIEWED FROM COMPONENT SIDE

MATERIAL:

HOUSING: PBT,UL94V-0,BLACK.
 TERMINALS BRACKET: PBT,UL94V-0,BLACK.
 SHIELD: C2680,T=0.20MM,NICKEL PLATING ON ALL AREA.
 TERMINAL: PHOSPHOR BRONZE C5210,T=0.35MM,
 6U" GOLD PLATING ON CONTACT AREA.

MECHANICAL:

DURABILITY: 750 CYCLES MIN.
 MATING FORCE: 23N MAX.
 OPERATING TEMPERATURE: -40°C~+85°C.
 STORAGE TEMPERATURE: -40°C~+85°C.
 ALL CRITICAL DIMENSIONS WITH "*"

WOHU 苏州沃虎电子科技有限公司
 Tel:4001048018 <http://www.wohu-tek.com>

| | | | | | |
|---------------------------------|--------------|-------------------|--|------------|-------------------------|
| TITLE: TAB-DOWN 1X1 1000BASE | SIZE A4 | UNITS MM[INCH] | GENERAL TOLERANCES UNLESS SPECIFIED | | APPROVED BY: JP.Gong |
| PART NO.: SYT111Q068DB1A1D | SACLE 1:1 | REV A0 | x±0.35 | x°±3.0° | CHECKED BY: TW.Xu |
| REMARK: | SHEET 1/3 | | .x±0.30 | .x°±2.0° | DESIGND BY: MQ.Qu |
| | | | .xx±0.25 | .xx°±1.5° | |
| | | | .xxx±0.10 | .xxx°±1.0° | |

REACH & RoHS
COMPLIANT

| | | | |
|------|-------------------|-------|------------|
| REV. | ECN / DESCRIPTION | BY | DATE |
| A0 | NEW | MQ.Qu | 2017.10.20 |

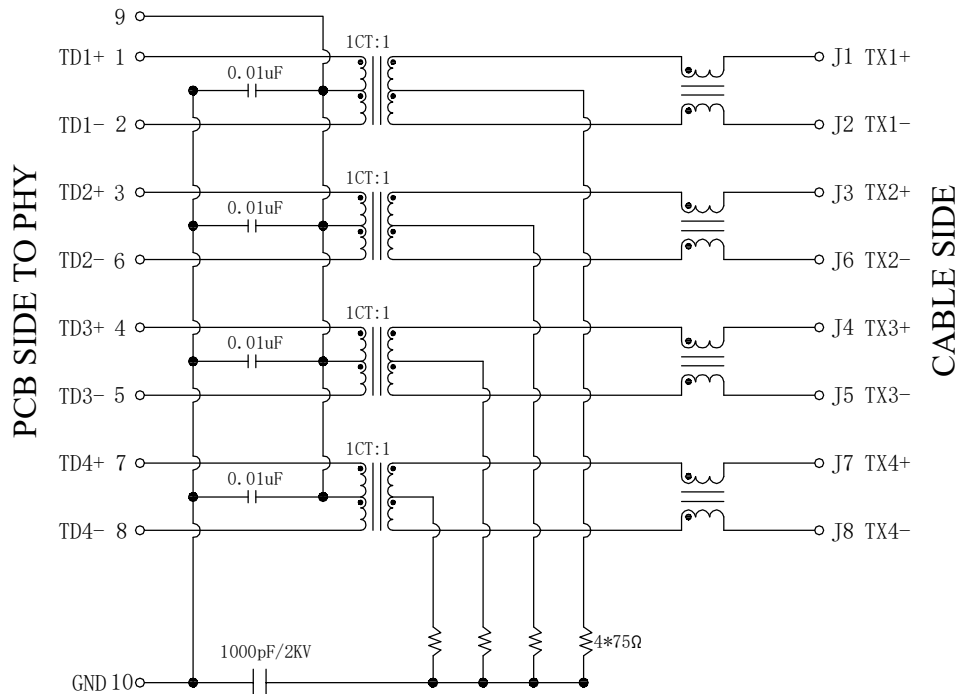

Electrical:

- Turn ratio: 1~2: J1~J2=1CT:1CT(±2%).
3~6: J3~J6=1CT:1CT(±2%).
4~5: J4~J5=1CT:1CT(±2%).
7~8: J7~J8=1CT:1CT(±2%).
- OCL: 350uH Min. at 100KHz 100mV 8mA DC.
- Insertion Loss: -1.0 dB Max 1~100MHz.
- Return loss: -18dB Min 1~30MHz;
-14dB Min 30~60MHz.
-12dB Min 60~80MHz.
-10dB Min 80~100MHz.
- Cross talk: -40dB Min 1~30MHz;
-35dB Min 30~60MHz;
-30dB Min 60~100MHz;
- CMR: -30dB Min 1~100MHz;
- Hi-Pot: 1500V AC & 2250V DC
6S 1mA PRI TO SEC

LED Specification

| Standard LED Color | LED Wavelength | Foward(A) | Foward(V) |
|--------------------|----------------|-----------|------------|
| Green | 568nm | 20mA | 1.85-2.45V |
| Yellow | 585nm | 20mA | 1.7-2.2V |

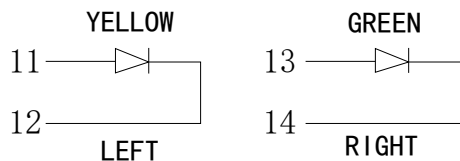

WOHU 苏州沃虎电子科技有限公司
Tel:4001048018 http://www.wohu-tek.com

| | | | | | |
|---------------------------------|--------------|-------------------|--|------------|-------------------------|
| TITLE: TAB-DOWN 1X1 1000BASE | SIZE A4 | UNITS MM[INCH] | GENERAL TOLERANCES UNLESS SPECIFIED | | APPROVED BY: JP.Gong |
| PART NO.: SYT111Q068DB1A1D | SACLE 1:1 | REV A0 | x±0.35 | x°±3.0° | CHECKED BY: TW.Xu |
| REMARK: | SHEET 2/3 | | .xx±0.25 | .xx°±1.5° | DESIGND BY: MQ.Qu |
| | | | .xxx±0.10 | .xxx°±1.0° | |

REACH & RoHS
COMPLIANT

PROFILE OF WAVE SOLDER

| REV. | ECN / DESCRIPTION | BY | DATE |
|------|-------------------|-------|------------|
| A0 | NEW | MQ.Qu | 2017.10.20 |

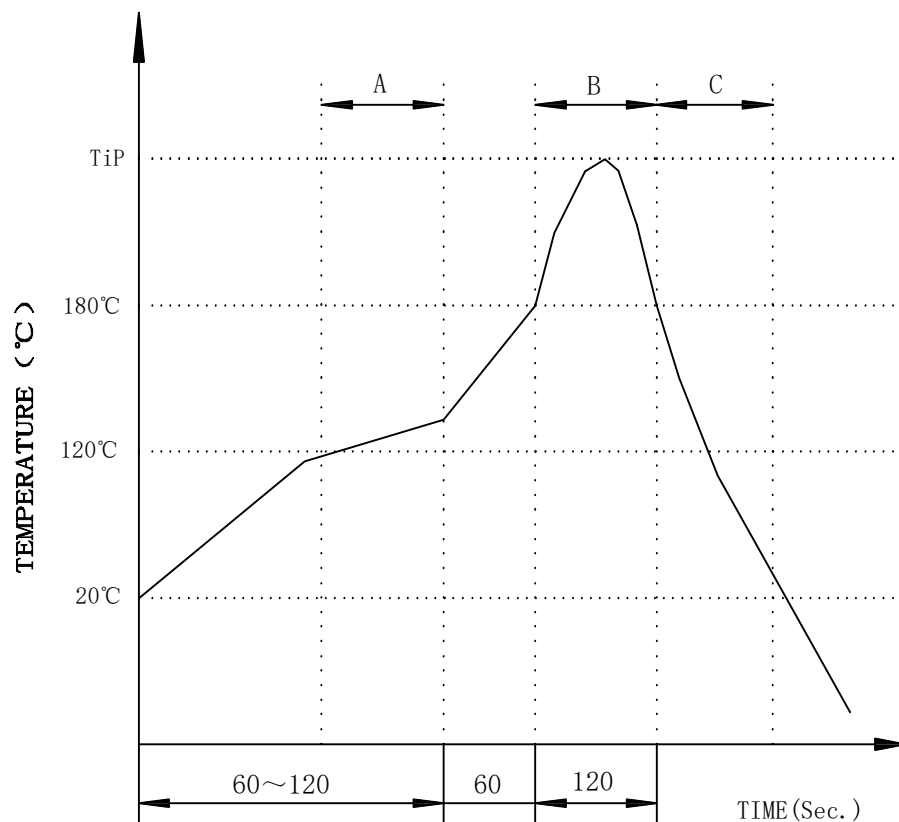

A.Preheating B.Soldering C.Gradual Cooling
 Tip temperature:260±5°C.
 Tip temperature time:5Sec Max.
 Tip melting point of Sn96.5/Ag3/Cu0.5:217°C.

Remarks: after wave soldering, the plastic positioning columns of the product which under the PCB will be slightly melted, but it won't affect its function.

WOHU 苏州沃虎电子科技有限公司
 Tel:4001048018 <http://www.wohu-tek.com>

| | | | | | |
|---------------------------------|--------------|-------------------|--|------------|-------------------------|
| TITLE: TAB-DOWN 1X1 1000BASE | SIZE A4 | UNITS MM[INCH] | GENERAL TOLERANCES UNLESS SPECIFIED | | APPROVED BY: JP.Gong |
| PART NO.: SYT111Q068DB1A1D | SACLE 1:1 | REV A0 | x±0.35 | x°±3.0° | CHECKED BY: TW.Xu |
| REMARK: | SHEET 3/3 | | .xx±0.25 | .xx°±1.5° | DESIGND BY: MQ.Qu |
| | | | .xxx±0.10 | .xxx°±1.0° | |